

ITEM NO.	PART NO.	DESCRIPTION	QTY.
1	H341	handle pivot, floor machine	1
2	H089	axle, 9.63" x .50" dia	1
3	H267	pivot block, TRex	2
4	H065	bushing, sleeve, 5/8 i.d. x 1.25" long	2
5	H066	bolt, shoulder 5/8" x 1.25", 1/2-13 thrs	2
6	H427	washer, wave	2
7	H665	wheel, 6" x 2", indented hub	2
8	H042	c-clip, 12mm, external	2
9	H157	spring, handle adjustment	1
10	H847	bushing, locking piston	1
11	H152	ring, retaining, internal 1 1/2"	1
12	H844	locking piston, handle adj.	1
13	H148	washer, 5/16", narrow	7
14	H843	locking arc, handle adjustment	1
15	H421	washer, 5/16" lock, s/s	10
16	H151	bolt, 5/16-18 x 3/4" Long SHCS	10
17	G107	o-ring, 13/16" o.d. x 1/8" width	1
18	H705	bolt, giude, locking piston	1
19	A102A	assembly, cleaning head, TRex JR	1
20	G014	seal, felt, T-REX	1
21	H126	plate, seal, head/ bell housing	1
22	P516A	bell housing, TRex JR	1
23	H768	bolt, 1/4-20 x 3/4" serrated hex flange, zinc	2
24	H485	handle, aluminum grip, black	1
25	G023A	o-ring, 6.5" o.d. x 1/8" width	1
26	C341A	motor & transmission, 1/2 hp, 1725 rpm, 50 hz, 230v, TRex JR	1
27	B139	rotary union	1
28	P517V	vacuum sight tube w/Cuff-Lynx, 90 deg, vinyl cuff	1
29	H230	screw, 10-32 x 1/2" phil pan head, s/s	7
30	H882	screw, 8 x 3/4 phil pan head, type a, s/s	2
31	E405A	knob, speed controller	1
32	P501	cover, front, switch housing, TRex	1
33	E363A	potentiometer, rotary	1
34	E382	pcb speed control	1
35	H258	switch box, T-REX	1
36	P574	knob, clear plastic, t-rex potent	1
37	E363	potentiometer, slide	1
38	B101	qd, brass, 1/4" m	1
39	B247	filter, in-line, 100 mesh, 1/4" mpt x fpt	1
40	B107	nipple, hex, 1/4"mpt x 1/4"mpt	1
41	AH122	sol hose, 1/4" x 7", 1/4 mpt x 1/4 fpt	1
42	B133-A	valve, brass, K, w/ trigger for wands	1
43	B103	elbow, 90 deg street, 1/4"mpt x 1/4" fpt	1
44	AH110	sol hose, 1/4" x 48" 1/4 msw x 1/8 mpt	1
45	H203	bolt, 1/4-20 x 1-1/4" hex head, s/s	4
46	H215	nut, hex, 1/4-20 s/s	1
47	H047	screw, 1/4-20 x 1/2", button, s/s, blk oxide	10
48	H164	grommet, 5/8" ID	2
49	E349	cord, female 38", 14/3 IEC320C13 plug	1
50	H247A	hook, hose restraint, T-REX	2
51	H159	cable, handle adj, 36"	1
52	H216	nut, lock, 1/4-20, nylon insert, s/s	1
53	H458	nut, lock, 10-32, thin, nylon insert	2
54	P529	spacer, lever, handle adj.	1
55	H257	lever, solution, T-REX	1
56	H167	switch, momentary	1
57	H127	bracket, mount, switch	1
58	H640	washer, internal star, 3/8" zinc	1
59	H384	washer, 3/8 flat, s/s	1
60	H263	lever, switch, T-REX	1
61	G040	grip, handle, vinyl	2
62	P522	handle, back half, T-REX	2

ITEM NO.	PART NO.	DESCRIPTION	QTY.
63	H261-B	handle, reinforcement, side, T-Rex	2
64	H261-A	handle, reinforcement, center, T-Rex	1
65	H222	screw, 10-32 x 1-1/4" phil pan head, s/s	2
66	P541	lockout, floor machine	1
67	H168	spring, lockout, floor machine	2
68	H260	cover, back, switch housing, TRex	1
69	G087	bumper w washer	2
70	H017	screw, 10-32 x 1.5", FHSCS, s/s	2
71	H018	screw, 10-32 x 1/2", FHSCS, s/s	3
72	H161	roll pin, 1 3/4" x 1/8"	2
73	H160	spring, switch/lever	2
74	H149	bolt, 5/16" shldr x 5/8" w/ 1/4-20 thrd	1
75	H839	lever, handle adj., floor machine	1
76	H144	strain relief, power cord, metal	1
77	E384	power cord, end, 15.5", 14/3	1
78	H249B-ss	tube, t-rex	1

ITEMS NOT SHOWN

PART NO.	DESCRIPTION	QTY.
P576A	star protector, TRex JR	1
E617A	power cord, ext, 25', 16/3 black	1
H051	wrench, flat, 5/8"	1
H053	tool, star remover, TRex	1
P568A	cord lock, "S", TRex	1
PH648	lubricant, super lube oil, 4 oz tube	1
ADM-TREX JR	manual, TRex JR	1

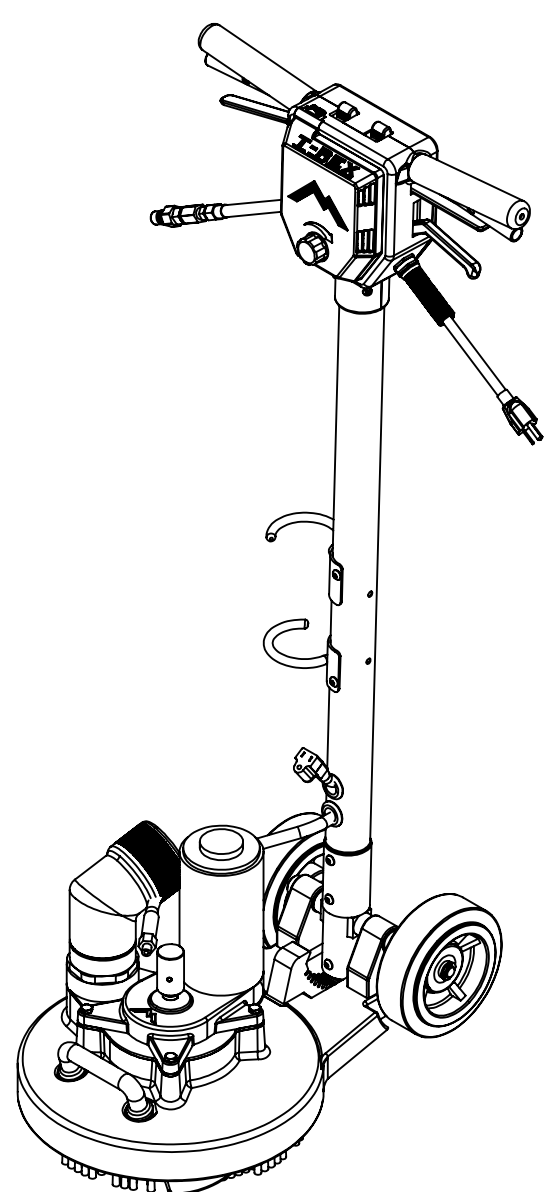

NAME	DATE	MYTEE 858-679-1191	
DRAWN M.LaBarbera	3/2014		
CHECKED		TITLE:	
COMMENTS:		T-REX JR-230	
<small>PROPRIETARY AND CONFIDENTIAL</small> <small>THE INFORMATION CONTAINED IN THIS DRAWING IS THE SOLE PROPERTY OF MYTEE LLC. ANY REPRODUCTION IN PART OR AS A WHOLE WITHOUT THE WRITTEN PERMISSION OF MYTEE LLC IS PROHIBITED.</small>		SIZE DWG. NO.	REV
		CTREX JR-230 OD	
SCALE: 1:24		DO NOT SCALE DRAWING	SHEET 1 OF 4

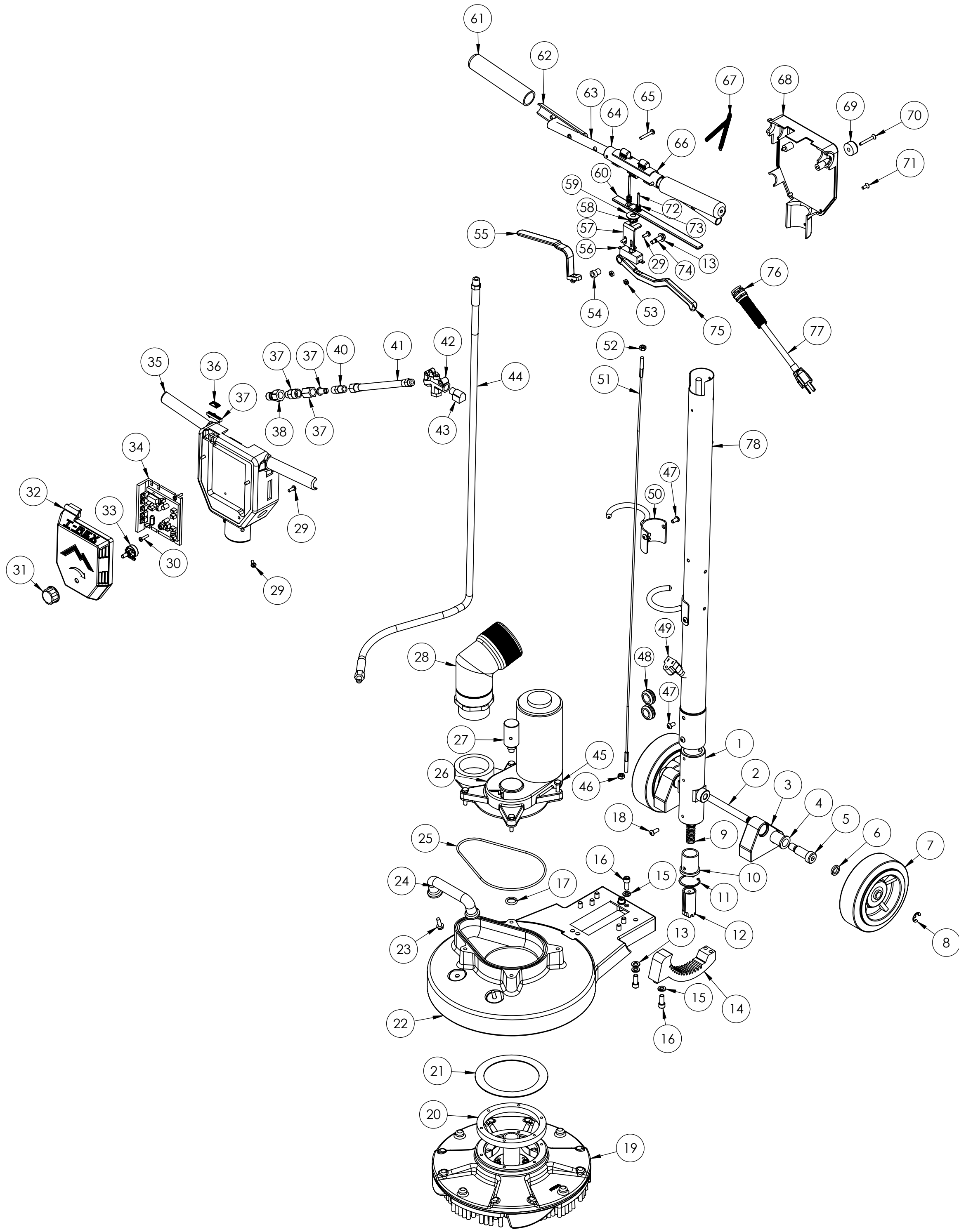

	NAME	DATE	MYTEE 858-679-1191		
DRAWN	M.LaBarbera	3/2014			
CHECKED			TITLE: T-REX JR-230		
COMMENTS:					
<small>PROPRIETARY AND CONFIDENTIAL</small> <small>THE INFORMATION CONTAINED IN THIS DRAWING IS THE SOLE PROPERTY OF MYTEE LLC. ANY REPRODUCTION IN PART OR AS A WHOLE WITHOUT THE WRITTEN PERMISSION OF MYTEE LLC IS PROHIBITED.</small>			SIZE	DWG. NO.	REV
			CTREX JR-230 OD		
SCALE: 1:24			DO NOT SCALE DRAWING	SHEET 2 OF 4	

ITEM NO.	PART NO.	DESCRIPTION	QTY.
1	G014	seal, felt, T-REX	1
2	P518A	manifold, upper, vac, T-REX JR	1
3	G037A	o-ring, 11.75 Od x 1/8" width	1
4	B161	manifold, upper, solution, T-REX	1
5	G027	o-ring, 1.75" o.d. x 1/8" width	2
6	H090A	manifold, lower vac, TRex JR	1
7	G099A	brush, tile, TRex JR	4
8	H186	screw, 10-32 x 3/4, phil, flat, countersunk, s/s, black	16
9	B157A	manifold, lower solution, TRex JR	1
10	B176	plug, 1/8" npt, countersunk hex	1
11	B639	jet, 1/8" mpt, 0.1-0.2, w/set screw, s/s	4
12	B217	check valve, 1/8" mpt x 1/8" fpt, 5 PSI	4
13	H036A	spray bar, 2.375", T-Rex	4
14	H248C	glide, TRex JR, s/s	4
15	H230	screw, 10-32 x 1/2" phil pan head, s/s	12
16	H018	screw, 10-32 x 1/2", FHSCS, s/s	20
17	H213	washer, 1/4" lock, s/s	4
18	H222	screw, 10-32 x 1-1/4" phil pan head, s/s	4

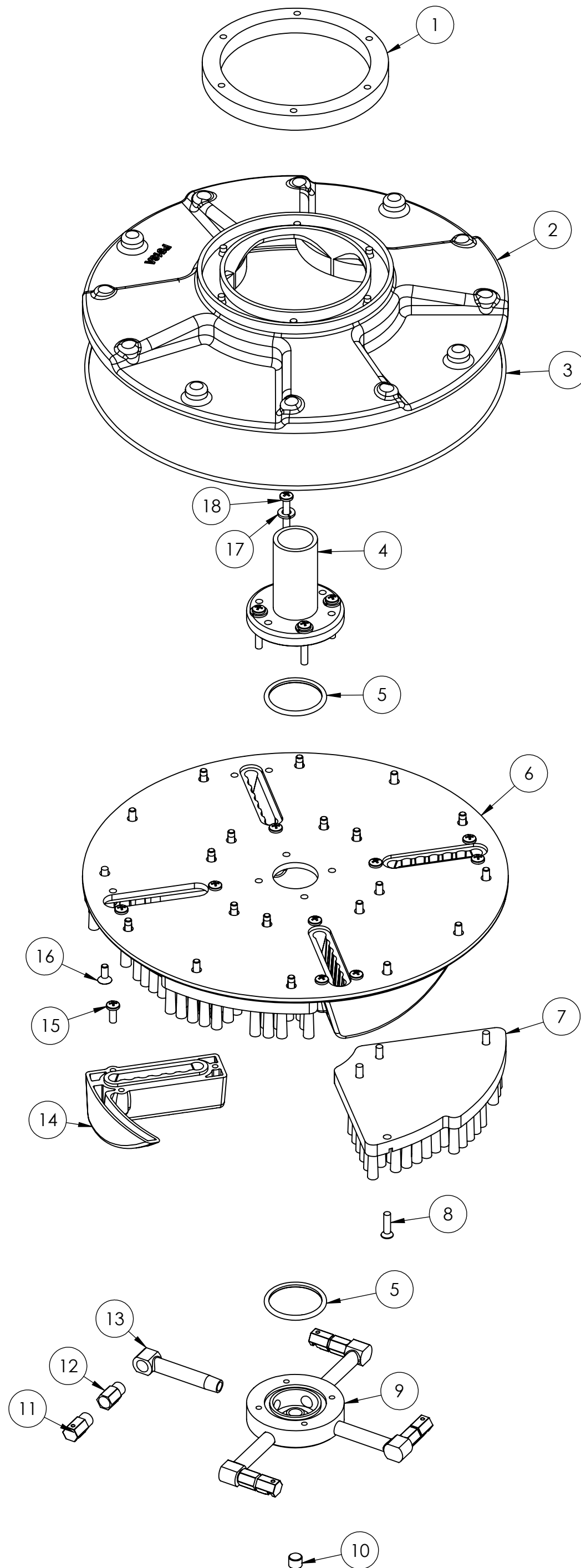

	NAME	DATE	MYTEE 858-679-1191		
DRAWN	M.LaBarbera	12/2014			
CHECKED			TITLE:		
COMMENTS:			assembly, cleaning head, TRex JR		
<small>PROPRIETARY AND CONFIDENTIAL</small> <small>THE INFORMATION CONTAINED IN THIS DRAWING IS THE SOLE PROPERTY OF MYTEE LLC. ANY REPRODUCTION IN PART OR AS A WHOLE WITHOUT THE WRITTEN PERMISSION OF MYTEE LLC IS PROHIBITED.</small>			SIZE	DWG. NO.	REV
			CTrex JR-230		B
SCALE: 1:4			DO NOT SCALE DRAWING	SHEET 3 OF 4	

REVISIONS

REV.	DESCRIPTION	DATE	APPROVED
OD	ORIGINAL DRAFT	3/2014	JFL

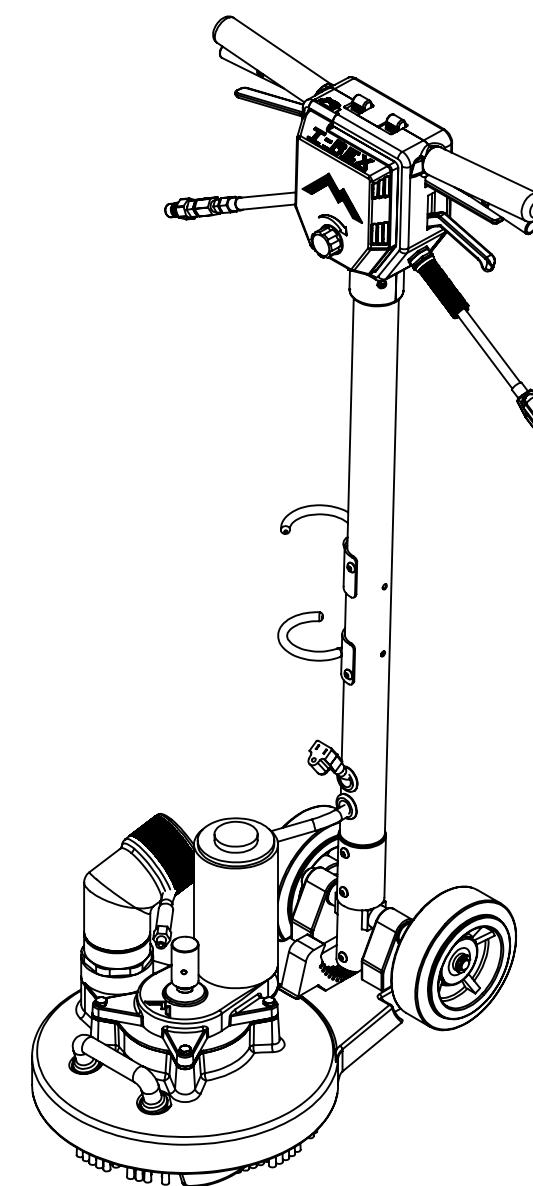

	NAME	DATE	MYTEE 858-679-1191	
DRAWN	M.LaBarbera	3/2014		
CHECKED			TITLE:	
COMMENTS:			T-REX JR-230	
PROPRIETARY AND CONFIDENTIAL THE INFORMATION CONTAINED IN THIS DRAWING IS THE SOLE PROPERTY OF MYTEE LLC. ANY REPRODUCTION IN PART OR AS A WHOLE WITHOUT THE WRITTEN PERMISSION OF MYTEE LLC IS PROHIBITED.			SIZE DWG. NO. CTrex JR-230 OD	REV
			SCALE: 1:24	DO NOT SCALE DRAWING SHEET 4 OF 4